

## COLUMN MOUNTED SUCTION DRAINER WITH PUMP

### P/N OE45111

**Column drainer (P/N OE39320) operated by pneumatic pump, equipped with:**

- ▶ pump with vacuum gauge P/N OE33070/A
- ▶ wall bracket P/N OE33115
- ▶ hose reel for suction with 10 m 1/2" hose P/N 430/41/AS
- ▶ P/N OE45560 set of probes (refer to pag. 22)
- ▶ P/N OE45540 probe ø 12 (refer to pag. 22)
- ▶ P/N OE45570 wall mounted probe kit

No.3 packing m<sup>3</sup> 0,250 kg 75

OVERALL DIMENSIONS P:290 H:2450 L:590 mm

### P/N OE45311

**Column drainer (P/N OE39320) operated by diaphragm pump Series 1/2", equipped with:**

- ▶ pump with vacuum gauge P/N OE33/2011NHHV2
- ▶ wall bracket P/N OE33590
- ▶ hose reel for draining with 10 m 1/2" hose P/N 430/41/AS
- ▶ P/N OE45560 set of probes (refer to pag. 22)
- ▶ P/N OE45540 probe ø 12 (refer to pag. 22)
- ▶ P/N OE45570 wall mounted probe kit

No.4 packing m<sup>3</sup> 0,260 kg 77

OVERALL DIMENSIONS P:290 H:2450 L:590 mm

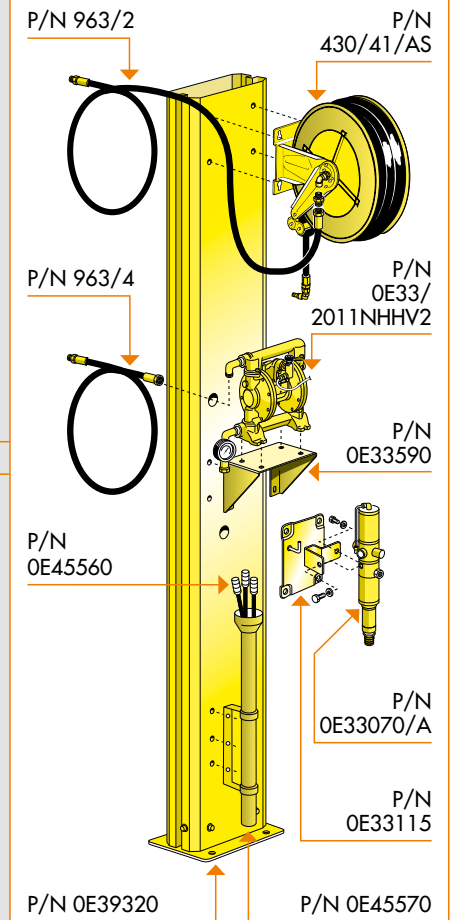
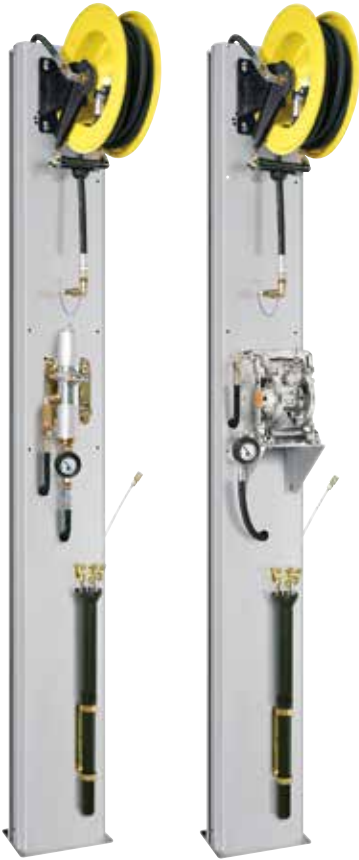

## TROLLEY SUCTION DRAINER WITH PUMP

### P/N OE45150

**Drainer-dispenser, with air pump and wheel-mounted for 30 - 60 Kg drums, equipped with:**

- ▶ P/N OE33070/A pump with vacuum gauge
- ▶ P/N OE80050 trolley for drums 30 - 60 kg
- ▶ 2 m suction/delivery hoses
- ▶ P/N OE45560 set of probes (refer to pag. 15)
- ▶ P/N OE45540 probe ø 12 (refer to pag. 22)

No.2 packing m<sup>3</sup> 0,80 kg 6819,5

OVERALL DIMENSIONS P:640 H:1000 L:500 mm

### P/N OE45180

**Drainer-dispenser, with air pump and wheel-mounted for 180 - 220 Kg drums, equipped with:**

- ▶ P/N OE33070/A pump with vacuum gauge
- ▶ P/N OE80200 trolley for drums 30 - 60 kg
- ▶ 2 m suction/delivery hoses
- ▶ P/N OE45560 set of probes (refer to pag. 22)
- ▶ P/N OE45540 probe ø 12 (refer to pag. 22)

No.2 packing m<sup>3</sup> 0,113 kg 32,1

OVERALL DIMENSIONS P:640 H:870 L:760 mm



| P/N                       |       | OE45150   | OE45180   |
|---------------------------|-------|-----------|-----------|
| Suction pump              | P/N   | OE33070/A | OE33070/A |
| Max air pressure at pump  | bar   | 6         | 6         |
| Noise level               | dB    | 81        | 81        |
| Suction hose              | ø x m | 1/2" x 2  | 1/2" x 2  |
| Draining hose             | ø x m | 1/2" x 2  | 1/2" x 2  |
| Suction speed at 70°-80°C | l/min | 1,5 - 2   | 1,5 - 2   |

⚠ The above items must not be used with flammable or corrosive fluids